

600V 0.5A AC TO DC PFM LED Lighting Controller**XL5004****Features**

- n Operate from a rectified 85V~265V AC mains supply.
- n 0.2V current sense voltage reference.
- n Maximum output current 500mA.
- n Support LED series 3~14 units.
- n Excellent line and load regulation.
- n Built in thermal shutdown function.
- n Built in UVLO function.
- n Built in current limiting function.
- n Built in LED open & short protection.
- n Built in soft-start circuit.
- n Available in SOIC-8 package.
- n PF > 0.9 (Power Factor) with suitable External components.

Applications

- n E27, GU10, GU5.3, B22 lamp device
- n LED daylight lamp
- n LED Lighting & LED LAMP
- n General purpose lighting

General Description

The XL5004 is a monolithic high voltage switching controller with PFM that is specifically designed to operate from a rectified 85V~265V AC mains supply.

The XL5004 is a high efficiency LED driver switching controller. The LED string is driven at DC constant current rather than constant voltage, thus providing constant current output and enhanced reliability.



SOIC-8

Figure1. Package Type of XL5004

600V 0.5A AC TO DC PFM LED Lighting Controller **XL5004**

Pin Configurations

NC	1	8	VSS
VDD	2	7	VSS
XL5004			
GATE	3	6	VSS
IS	4	5	VSS

Figure2. Pin Configuration of XL5004 (Top View)

Table 1 Pin Description

Pin Number	Pin Name	Description
1	NC	No Connected.
2	VDD	The chip supply voltage.
3	GATE	Output HV-NMOS gate driver
4	IS	Current Sense Pin. (The current sense voltage is 0.2V)
5,6,7,8	VSS	The chip reference ground.

Function Block

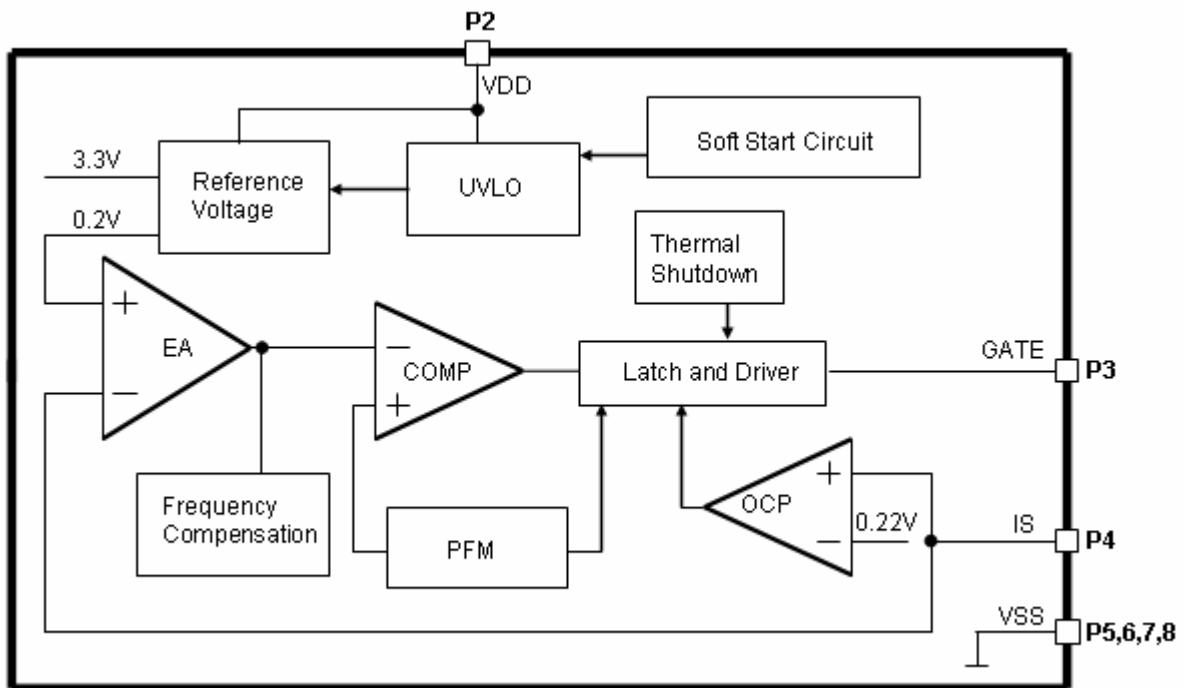
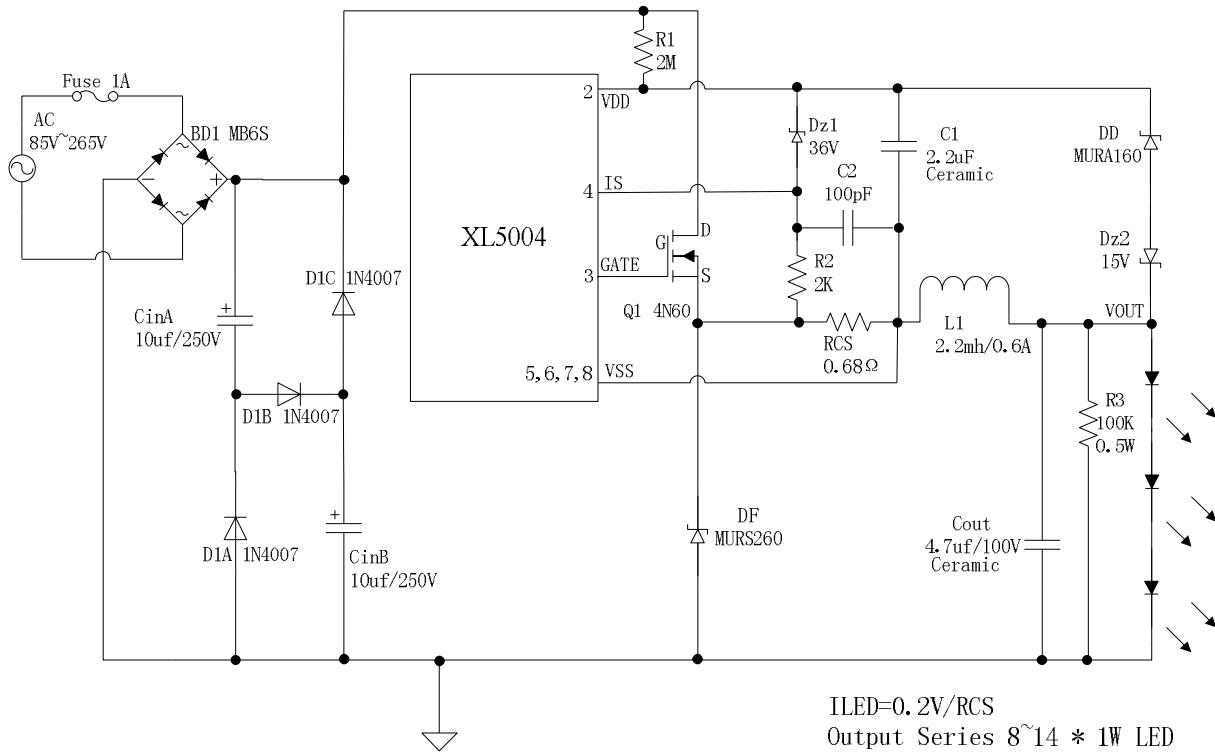

Figure3. Function Block Diagram of XL5004

600V 0.5A AC TO DC PFM LED Lighting Controller **XL5004**

Typical application circuit with PFC solution

CinA/B & D1A/B/C For Power Factor Correction (PFC)
 RCS For Output LED Constant Current & LED Short Protection
 Dz1 & R2 For Output LED Open Protection
 DD C1 For XL5004 Bootstrap Supply



I_{LED}=0.2V/RCS
 Output Series 8~14 * 1W LED

- [1] Input AC 85V~265V Mains Supply.
- [2] Output Constant Current Drive Series 8~14 * 1W LED.
- [3] Support Output LED Open & Short Protection.

Figure4. XL5004 Typical Application (Mains supply 8~14W LED saving energy lamp)

600V 0.5A AC TO DC PFM LED Lighting Controller	XL5004
---	---------------

Ordering Information

Package	Temperature Range	Part Number	Marking ID	Packing Type
		Lead Free	Lead Free	
		XL5004E1	XL5004E1	Tube
		XL5004TRE1	XL5004E1	Tape & Reel

XLSEMI Pb-free products, as designated with “E1” suffix in the par number, are RoHS compliant.

Absolute Maximum Ratings (Note1)

Parameter	Symbol	Value	Unit
Input Voltage	V _{in}	-0.3 to 600	V
Power Dissipation	P _D	Internally limited	mW
Thermal Resistance (SOP-8L) (Junction to Ambient, No Heatsink, Free Air)	R _{JA}	100	°C/W
Operating Junction Temperature	T _J	-40 to 125	°C
Storage Temperature	T _{STG}	-65 to 150	°C
Lead Temperature (Soldering, 10 sec)	T _{LEAD}	260	°C
ESD (HBM)		3000	V

Note1: Stresses greater than those listed under Maximum Ratings may cause permanent damage to the device. This is a stress rating only and functional operation of the device at these or any other conditions above those indicated in the operation is not implied. Exposure to absolute maximum rating conditions for extended periods may affect reliability.

600V 0.5A AC TO DC PFM LED Lighting Controller	XL5004
---	---------------

XL5004 Electrical Characteristics

T_a = 25°C; unless otherwise specified. Reference test circuit figure5

Symbol	Parameter	Test Condition	Min.	Typ.	Max.	Unit
VIS	IS Voltage	VAC = 85V to 265V, Iled=0.3A, Pout=8W	190	200	210	mV
Efficiency	η	VAC=110V, Iled=0.3A, Pout=12W	-	88.2	-	%
Efficiency	η	VAC=220V, Iled=0.3A, Pout=12W	-	88.0	-	%

Electrical Characteristics (DC Parameters)

Parameters	Symbol	Test Condition	Min.	Typ.	Max.	Unit
Input operation voltage	VIN		100		400	V
Quiescent Supply Current	I _q	Figure5, VAC=220V Iled=0		0.15	0.3	mA
Switching Frequency	Fosc	Figure5 (12*1W) VAC=220V	53.3	66.6	79.9	KHz
Max. Duty Cycle	D _{MAX}			50		%
Thermal Shutdown	OTP	T _j		165		°C
Thermal Shutdown Window				25		°C

600V 0.5A AC TO DC PFM LED Lighting Controller XL5004

[1] Typical application circuit & with PFC solution (8W~14W)

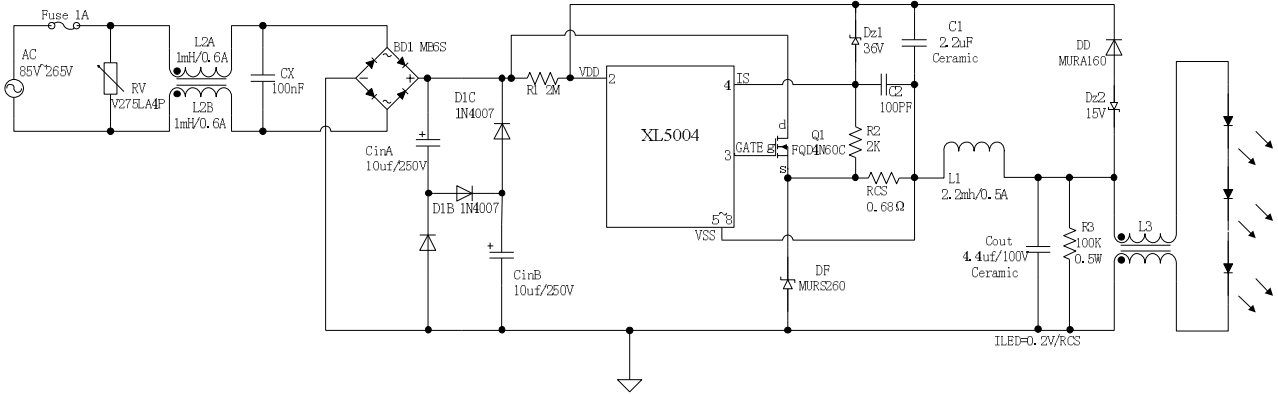

Figure5. XL5004 System Application for AC LED LAMP

Figure5 system parameter reference table as follows:

VIN=110Vac						
1W LED Series	Pin(W)	PF	Vout (V)	Iout (mA)	Fosc(KHz)	Effi ency(%)
8	8.9	0.882	26.25	298	54.3	87.9
9	9.9	0.876	29.25	297	58.1	87.8
10	10.9	0.879	32.44	296	62.5	88.1
11	11.8	0.880	35.44	294	65.7	88.3
12	12.8	0.876	38.55	293	67.5	88.2
13	13.7	0.861	41.77	294	71.4	89.6
14	14.5	0.863	44.84	289	76.9	89.4
VIN=220Vac						
1W LED Series	Pin(W)	PF	Vout (V)	Iout (mA)	Fosc(KHz)	Effi ency(%)
8	10.2	0.879	26.60	328	50.0	85.5
9	11.3	0.868	29.70	327	54.0	85.9
10	12.3	0.878	32.89	325	58.8	86.9
11	13.3	0.857	35.95	322	63.2	87.0
12	14.2	0.876	39.06	320	66.6	88.0
13	15.2	0.878	42.24	319	70.0	88.6
14	16.3	0.872	45.28	317	73.7	88.1

600V 0.5A AC TO DC PFM LED Lighting Controller **XL5004**

[2] Typical application circuit & with PFC solution (3W~7W)

CinA/B & D1A/B/C For Power Factor Correction (PFC)
 RCS For Output LED Constant Current & LED Short Protection
 Dz1 & R2 For Output LED Open Protection
 DD C1 For XL5004 Bootstrap Supply

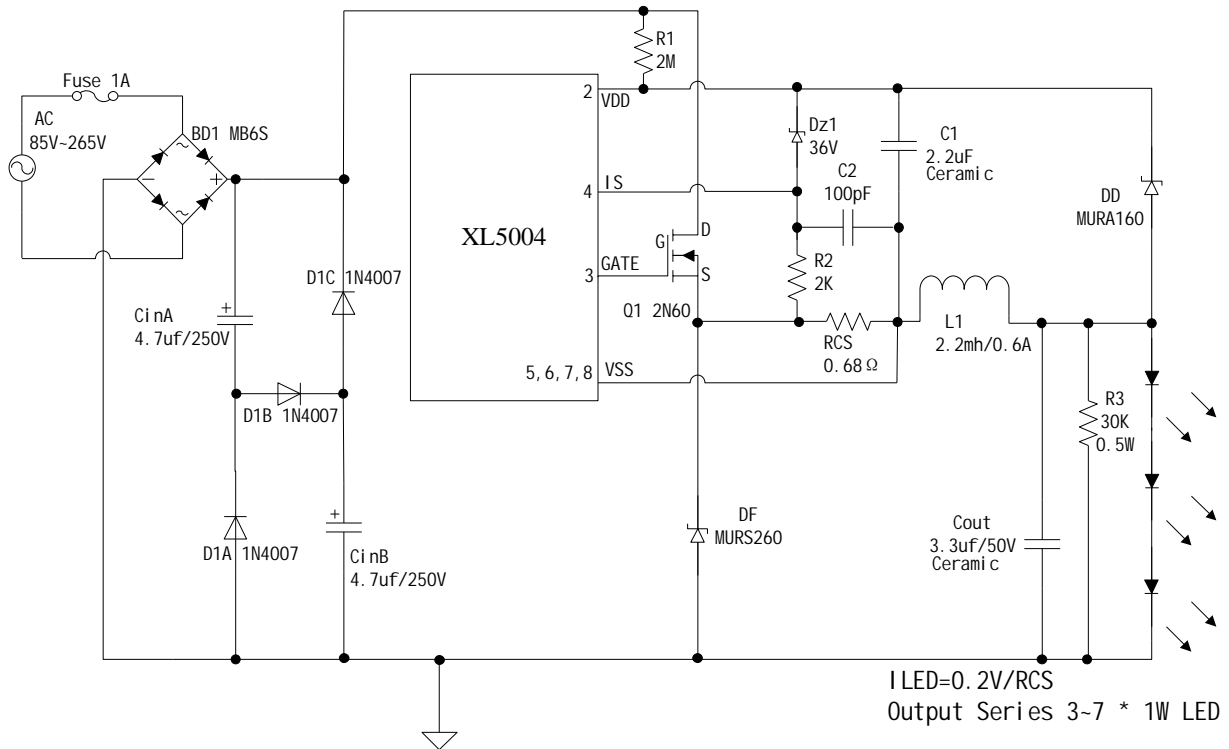

- [1] Input AC 85V~265V Mains Supply.
- [2] Output Constant Current Drive Series 3~7 * 1W LED.
- [3] Support Output LED Open & Short Protection.

Figure6. XL5004 System Application for AC LED LAMP

600V 0.5A AC TO DC PFM LED Lighting Controller **XL5004**

Package Information
SOP8 Package Mechanical Dimensions

SOIC-8

Unit: mm(inch)

